



INSTRUCTION MANUAL

A'PEX S1 DAMPER

Height Adjustable Coilover Damper Kit

PRODUCT CODE - 268AZ018

(Table 1) Vehicle Application

Application Vehicle	Vehicle Model	Engine Model	Year
MAZDA RX8	SE3P	13B-MSP	2003-

1. Preface

Thank you for purchasing the *A'PEX S1 DAMPER* system. These shocks have been designed to replace the factory shock absorbers. Please read the instruction manual carefully and refer to the contents of this manual for proper installation and use. **DUE TO THE TECHNICAL NATURE OF THE PRODUCT, AND RISK OF INJURY OR DEATH AS A RESULT OF IMPROPER INSTALLATION, WORK SHOULD ONLY BE PERFORMED BY AN EXPERIENCED INSTALLER.** Consult with the dealer of purchase for a qualified installation facility near you. Please contact the dealer of purchase with a valid receipt if the product has been damaged during shipping or has a manufacturer defect. Never disassemble or discharge the shock absorber assemblies. All warranties expressed or implied will be voided if evidence of tampering exists. This product must be returned complete with all relevant packaging included for warranty to be honored.

Installation Precaution

- Please read the contents of this manual thoroughly before attempting installation.
- This shock absorber system has been designed to be used with the factory upper mounts. Do not use upper mounts from other manufacturers with this product.
- This manual is intended for experienced installers with adequate knowledge of vehicle repair, service and installation. Installation should be performed at a qualified service center or dealer with proper equipment.
- Be sure to keep this manual stored in a safe place for future reference.
- In the case of transferring vehicle or product ownership, give this manual to the new owner.

Product Number
4298-90E0-Z4

2. Table of Contents

	Page
1. Product Name, Product Code, Vehicle Application, Preface	1
2. Table of Contents	2
3. Table 2 – Signal Words and Their Meanings	2
4. Check First	2
5. Table 3 – Contents Table	3
6. Table 4 – Manual Information	3
7. A'PEX S1 DAMPER Usage	3
8. Installation Process	4
9. Ride Height Adjustment	5
10. Damping Adjustment	5
11. Vehicle Maintenance	5
11. Contact	5
12. Assembly Diagram – Front	6
13. Assembly Diagram – Rear	7

3. Signal Words and Their Meaning

We have included various cautions and recommendations to prevent harm to you or others. These safety recommendations have been separated into categories with SIGNAL WORDS to denote the importance of each point. Please be sure to read all of these cautionary points to ensure safe installation of this product. Do not attempt installation of this product without clear understanding of the risks involved.

(Table2)

Signal Word	Signal Word Meaning
⚠DANGER	Failure to comply will likely result in potential death or severe injury to the user and/or third parties.
⚠WARNING	Failure to comply may result in potential death or severe injury to the user and/or third parties.
⚠CAUTION	Failure to comply may lead to personal injury, damage to the product, and other property.
PLEASE	Failure to comply may affect product performance and may lead to product damage.

4. Check First

- *A'PEX S1 DAMPERS* are engineered according to specific vehicle applications. Please confirm that this product matches with the vehicle application you have chosen.
- This product is composed of components listed in the contents table. Please notify the dealer of purchase for any missing or damaged components.
- Notify your dealer of purchase for any damaged or missing components before installation.
- Installation of the shock absorbers should be performed at an experienced shop with an adequately equipped facility. A'PEX CO., LTD. and its affiliate companies are NOT responsible for injury or damages incurred from the improper installation of this product.

5. (Table3) Contents Table

Part Code	Product Name	Qty	Comments
268AZ018 (Full Kit)	FRONT (Right and Left are identical) SHOCK ABSORBER	2	
	REAR (Right and Left are identical) SHOCK ABSORBERS	2	
	SPRING (FRONT)	2	200mm-10kgf/mm (8inch-560lb/in)
	SPRING (REAR)	2	155mm-8kgf/mm (6inch-450lb/in)
	HELPER SPRING (REAR)	2	
	HELPER SEAT (REAR)	2	
	RUBBER UPPER MOUNT (FRONT)	1set	
		INSTRUCTION MANUAL	1

6. Manual Information

No	Print Date	Product Number	Version
1	Feb 01 2010	4298-90E0-Z4	Ver.1

7. A'PEX S1 DAMPER Usage

 DANGER

- Contents under extremely high gas pressure. Avoid storing this unit near high temperatures. Failure to comply may result in explosion and personal injury.
- Use care when handling the springs. Handling the springs using tools, hitting the spring with a hammer, grinding the spring with a file, and cutting the spring will compromise the integrity, reliability, and performance of the spring

 WARNING
--

- This product has been engineered exclusively for the vehicle listed above. **DO NOT** install or use this product with any other type of vehicle. Failure to heed this warning may result in injury and death.
- Installation of this product should be performed using the **VEHICLE SERVICE MANUAL** procedures for the applicable vehicle. Be sure to follow A'PEX recommended installation procedures when they differ from the factory procedure.
- Installation should **ONLY** be performed by an experienced installer. Failure to do so may result in improper installation and may lead to accidents. Installation should be performed at a certified and established repair center.
- **PLEASE USE THE FACTORY UPPER MOUNTS** for the **S1 DAMPERS**, unless upper mounts for specific use are included as part of the system. A'PEX CO., LTD. and its affiliate companies are **NOT** responsible for injuries or damages incurred through the use of other manufacturer's products.
- Always use the included bump stops. Failure to do so may result in poor performance and damage to the shocks.
- Never excessively lower the vehicle. This could lead to suspension failure, damage to the fender, wheels, and tires, and product failure. If the vehicle is lowered excessively, stop the vehicle and raise the ride height as soon as possible at a qualified repair shop.
- Be sure to test drive the vehicle after installation to double check installation. Retighten bolts and other components after the test drive, after the first 100 km (60 miles) of driving, and periodically as part of regular maintenance procedure.
- Be sure to adjust ride height to conform to any local and federal laws. A'PEX is not responsible for any citation resulting from illegal adjustment of ride height. Consult your local law enforcement agency to confirm legal ride height and headlight/bumper height.

 CAUTION
--

- Debris from driving on dirt and snow can lead to oil leaks from the shocks. Be sure to check for excess debris on shaft of the shock absorber to prevent this from happening.

PLEASE

- Strut-type shock absorbers have a small amount of clearance between the cylinder case and the outer case to minimize friction. Such models may emit a slight noise or minor vibration. This is normal. In case of unusually excessive noise, check for proper installation of the shocks and check for any problems with the vehicle first. In the unlikely event of a product failure, discontinue use immediately. Write down the product code, vehicle type, serial and lot numbers, and contact your dealer of purchase.

The following sounds are normal:

- Shock Absorber Damping Sound: A whooshing sound coming from within the shock as shock absorber piston is moved up and down.
- Low-Speed Click Sound: When going over bumps and transitions at low speeds, there may be a small click or clunk sound from the damper assembly.
- Inverted Strut-Type Case Sound: A slight rattling sound coming from the cylinder case of inverted strut assemblies.

8. Installation Process

DANGER

- **Never tighten the upper mount with an impact wrench.** Tighten the upper mounts according to the recommended torque specification listed below. Failure to do so may result in damage to the upper mount and bolt and may cause product failure.
- **Always refer to the vehicle service manual when installing this product. Always use the appropriate tools and tighten to recommended torque specifications. Be sure to follow A'PEX recommended installation procedures when they differ from the factory procedure.**
- **Always tighten the Lower Spring Seat and Lock Nuts to the recommended torque specifications after confirming that there is no spring play with the lower spring seat. Failure to do so may cause the Lock Nut to loosen and lead to accidents.**
- **Some shock absorbers differ in construction for the left and right sides. Be sure to confirm proper sides by using the Assembly Diagrams. Improper installation may lead to serious damage and accidents.**

Bolt size	Recommended torque	Comments
M10×1.25	17.6~23.5N·m (1.8~2.4kgf·m)	Standard Type
M12×1.25	27.4~34.3N·m (2.8~3.5kgf·m)	Standard Type
M12×1.25	36.3~50.0N·m (3.7~5.1kgf·m)	Strut type

Lower Spring Seat Torque Specifications

Components	Tightening Torque	Comments
Lower Spring Seat, Lock Nut	Over 34.3N·m (3.5kgf·m)	All Vehicles

WARNING

- **Be sure to use the included nylon nut and always tighten to recommended torque specifications.**
- **Never use an impact wrench to install this product. Failure to heed this advice may result in damage.**
- **Always perform an alignment on the vehicle after installation. Failure to do so can lead to abnormal or premature tire wear, poor handling performance, as well as serious accidents.**

CAUTION

- **After installation, be sure to check if all nuts and bolts have been tightened to manufacturer specifications. Also, check for ample clearance between the tire, fender, and other related suspension components.**
- **Never hold the piston rod or cylinder case using tools. This could scratch and damage components and lead to oil leaks from the piston rod and cylinder case.**
- **Hand-tighten the lower spring seat against the spring so that there is no play between the spring and seat. Use the assembly diagram to adjust the lower seat to the recommended ride height.**
- **The recommended height is for reference purposes only. Vehicle condition, grade, year, and options will affect actual height. Please adjust the lower spring perch to obtain recommended trim height.**
- **When removing the spring form the shock absorber, lower the spring seat to relieve pre-loaded tension, or use a spring compressor. Be sure not to scratch the threaded outer case when using a spring compressor.**
- **Always test drive the vehicle and check for any loose components or clearance problems.**

9. Ride Height Adjustment

CAUTION

- Always use a lift, or jacks in conjunction with jack stands when adjusting ride height. Raising the vehicle without the proper equipment may cause the unstable vehicle to fall, leading to serious injury and/or death.
- Be sure to adjust the left and right side height of the vehicle evenly and perform an alignment on the vehicle. When adjusting the ride height, it is best to use an alignment tester and corner weight gauge. Improper alignment and unbalanced ride height can lead to abnormal or premature tire wear, poor handling performance, as well as serious accidents.
- Be sure to tighten the lock nut according to the torque specifications shown in section 8 of this manual. A loose lock nut is extremely dangerous. Please be sure to tighten the nut using the included wrench, and check the lock nuts regularly during scheduled maintenance.
- Lowering the vehicle too much will result in inadequate stroke for the shock. This can lead to unstable handling and could result in an accident. Adjust the vehicle ride-height to a well-balanced height.

There are two ways to adjust ride height. The recommended method is by adjusting the Front/Rear Adjust Case. This will allow ride height to be changed without affecting the spring preload. The other option is to raise or lower the Lower Spring Seat. However, drastic changes in ride height should not be done in this manner, as excessive preloading will result in improper damping and unnecessary strain on the components. Excessively lowering the Lower Spring Seat much will create play in the spring, which results in a dangerous situation and will cause damage to the components.

10. Damping Adjustment

CAUTION

- This suspension system is 20-way damping adjustable. Do not use excessive force or force the adjustment knob beyond the setting range. Failure to heed this warning will cause damage to the internal valve assembly thereby causing the damping unit to fail.

Damping adjustment is performed by turning the knob on the top of the shock absorber assembly. On inverted strut-type shock absorber systems, the adjustment knob is located on the bottom of the assembly. If you are not sure where the adjustment knob is located on your system, please refer to the diagrams at the end of this manual. All S1 Dampers are 20-way adjustable, where the hardest/stiffest setting is the full clockwise position (referred to as position 1), and the softest setting is the full counter-clockwise position (position 20). From the factory, the S1 Dampers are shipped with the damping settings at position 10.

11. Vehicle Maintenance

PLEASE

- Installation of this A'PEX S1 DAMPER will most likely cause the vehicle alignment to change. Be sure to complete an alignment procedure on your vehicle after installation. Driving with improper alignment will cause abnormal or premature tire wear, and poor handling performance.
- The A'PEX S1 DAMPER allows for a wide range of vehicle ride heights. However, excessive vehicle lowering may cause dangerous handling characteristics and is not recommended. Please adhere to the recommended vehicle ride heights as close as possible.
- Excessive ride height changes can put excessive strain on the axles of a vehicle. Be sure to check for adequate grease and lubrication on the axles.
- Excessive lowering may cause problems in tire and fender clearance as well as clearance with other suspension components.
- Spring type will differ according to vehicle application. We recommend the springs included in the CONTENTS TABLE. Use of different springs must take vehicle type, acceptable stroke, and vehicle weight into account. Please contact your local dealer for more assistance.
- Shock absorbers will wear according to usage. Life expectancy will range according to driving style. Please contact your dealer of purchase to obtain information on recharging the shocks.
- Always rebuild and/or replace all 4 shocks at once.

12. Contact

APEX CO.,Ltd.
5-21-3, Fujimi, Sagamihara-city,
KANAGAWA 229-0036 JAPAN
+81-42-768-8148

APEX Integration Inc.
1449 West Orange Grove Ave, Unit A
Orange, CA 92868 USA
+1-714-685-5700

APEX Pac. Co. Pte. Ltd.
163, Pasir Panjang DistriPark,
#01-20, Pasir Panjang Road,
Singapore 118498
+65-6257-5977

268AZ018 Assembly FRONT

< ⚠ CAUTION >

The recommended height is for reference purposes only. Vehicle condition, grade, year, and options will affect actual ride height. Please adjust lower spring seat to attain recommended vehicle height.

* Fig #1

<What is trim height?>

→ Trim height(T/H) is the distance between the center of the wheel and the top of the fender arch when the vehicle is on the ground.

* Be sure to settle suspension after lowering.

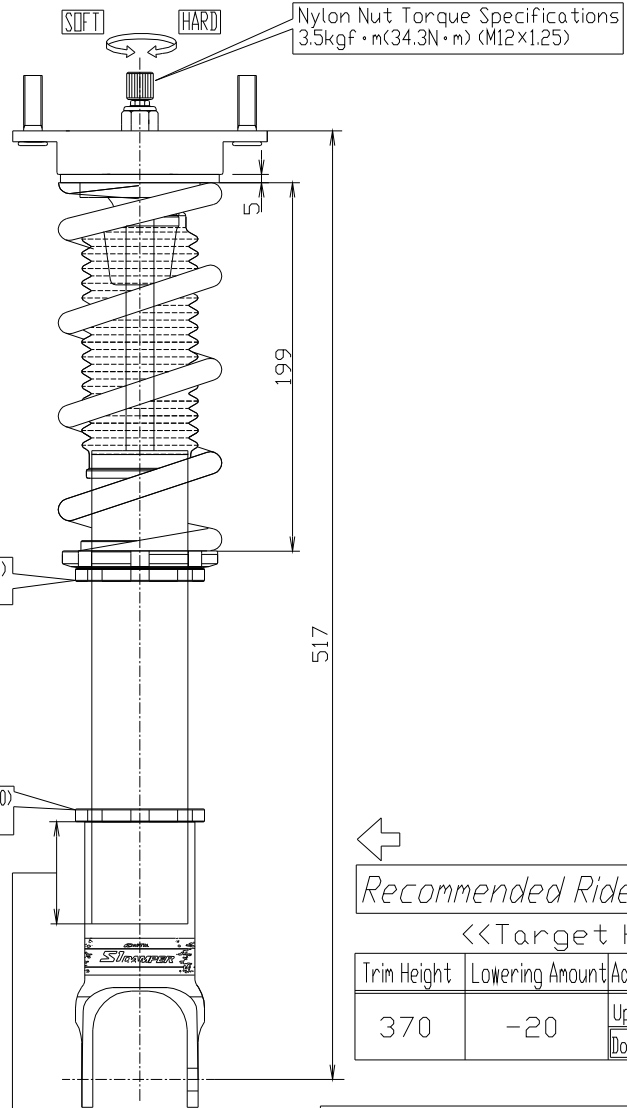
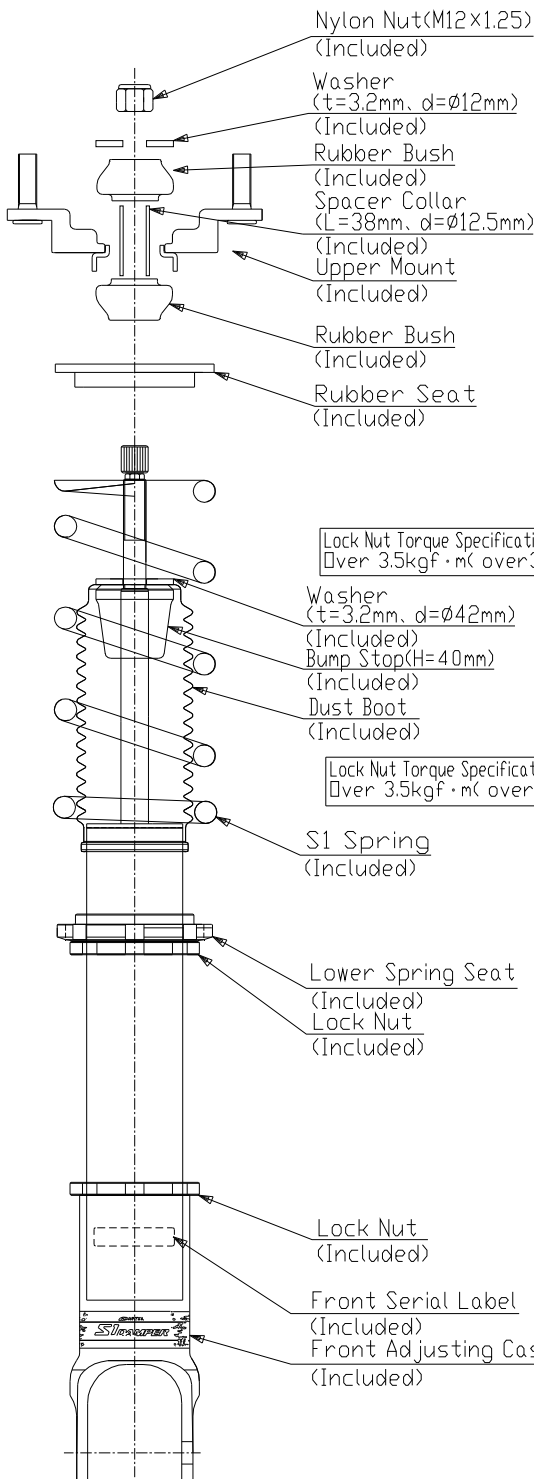
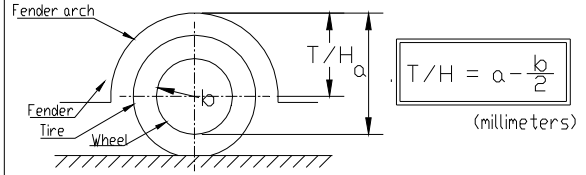

←

Recommended Ride Height

<<Target Height>>

Trim Height	Lowering Amount	Adjustment Range
370	-20	Up Side approx. 65 Down Side approx. 35

* Fig #3

The recommended height figures listed above have taken the total shock stroke length into account. When setting the shocks to a custom height, be sure to check clearance levels between the shock and vehicle. Make sure that the shock absorber has ample clearance with the wheel.

< ⚠ WARNING >

Keep the Adjust Case insertion position over 20mm as shown to the above, (Figure on the diagram denotes factory settings.) Imported setting of this position may cause maximum stroke and damage the shock absorber.

268AZ018 Assembly REAR

< ⚠ CAUTION >

The recommended height is for reference purposes only. Vehicle condition, grade, year, and options will affect actual ride height. Please adjust lower spring seat to attain recommended vehicle height.

*Fig #1

<What is trim height?>

→Trim height(T/H) is the distance between the center of the wheel and the top of the fender arch when the vehicle is on the ground.

*Be sure to settle suspension after lowering.

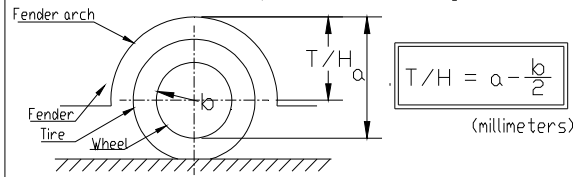

< ⚠ WARNING >

Keep the Adjust Case insertion position over 20mm as shown to the above, (Figure on the diagram denotes factory settings.) Imported setting of this position may cause maximum stroke and damage the shock absorber.

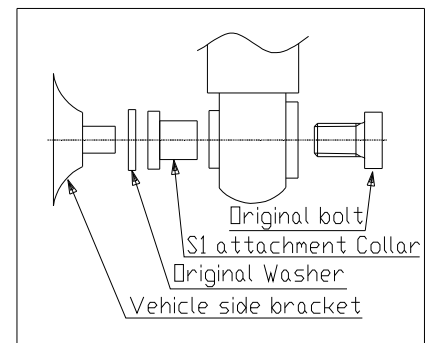
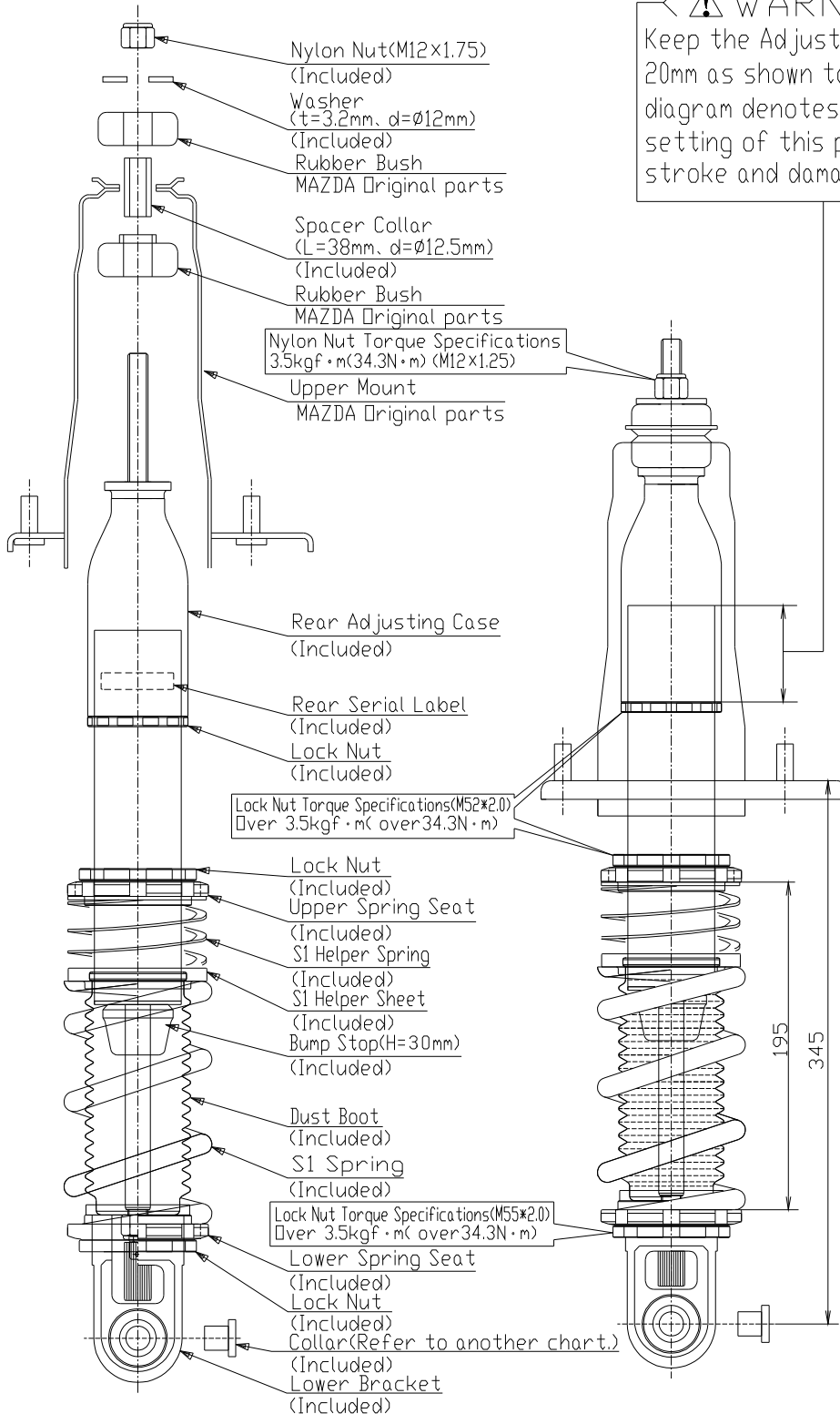

Recommended Ride Height

<<Target Height>>

Trim Height	Lowering Amount	Adjustment Range
380	-20	Up Side approx. 35 Down Side approx. 30

*Fig #3

The recommended height figures listed above have taken the total shock stroke length into account. When setting the shocks to a custom height, be sure to check clearance levels between the shock and vehicle. Make sure that the shock absorber has ample clearance with the wheel.